

# KOBELCO

SK180LC-10 SK180N-10

## SK180<sub>LC</sub> SK180<sub>N</sub>

■ Bucket Capacity:

0.63 m<sup>3</sup>

■ Engine Power:

100 kW/2,000 min<sup>-1</sup>

■ Operating Weight:

18,800 – 20,500 kg



**We Save You Fuel**  
Achieving a Low-Carbon Society

# Power Meets Efficiency



**SK180<sub>LC</sub> SK180<sub>N</sub>**



To urban centers, and to mines around the world. Kobelco's all-out innovation brings you durable earth-friendly construction machinery that's equal to any task, at sites all over the planet. Increased power and even greater fuel economy bring higher efficiency to any project. Kobelco SK180LC SK180N machines are also more durable than ever, able to withstand the rigors of the toughest job sites. It all adds up to new levels of value that are a step ahead of the times. Also, this machine conforms to Stage IV Exhaust Emission Standards, thanks to its significantly reduced NOx\* emissions. While focusing on the global environment of the future, Kobelco offers next-generation productivity to meet the need for lower life cycle costs and exceed the expectations of customers the world over.

\*NOx: Nitrogen Oxide



# Evolution Continues, with Improved Fuel Efficiency



## Efficient Performance!

### Top-Class Powerful Digging

The highly efficient hydraulic system minimizes fuel consumption while maximizing power. With nimble movement and outstanding digging power, this excavator improves job productivity.

## Hydraulic System: Revolutionary Technology Saves Fuel

### ECO-mode: Engineered for Economy

Kobelco's ECO-mode maximizes the operating efficiency of the engine and other components to achieve much greater fuel efficiency. Just press a button to choose the operation mode best suited to the task at hand and the working conditions.

■ Optimal operation with three modes

- H** H-mode ••• Maximum power for maximum productivity on your toughest jobs
- S** S-mode ••• Ideal balance of productivity and fuel efficiency for a range of urban engineering projects
- E** ECO-mode ••• Minimum fuel consumption for utility projects and other work that demands precision

## Hydraulic Circuit Reduces Energy Loss

We have made every effort to enhance fuel efficiency by minimizing hydraulic pressure resistance, improving the hydraulic line layout to control friction resistance loss and minimizing valve resistance.

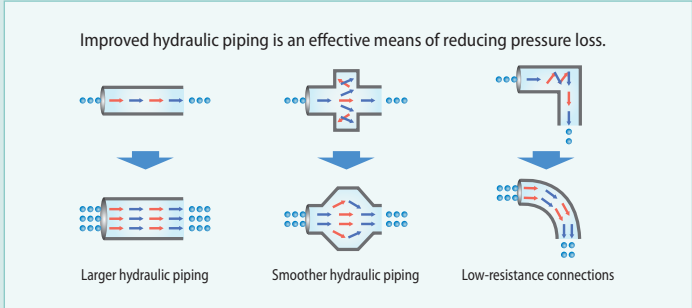

## AIS (Auto Idle Stop)

If the safety lock lever is left up, the engine will stop automatically. This eliminates wasteful idling during standby, saving fuel and reducing CO<sub>2</sub> emissions as well.

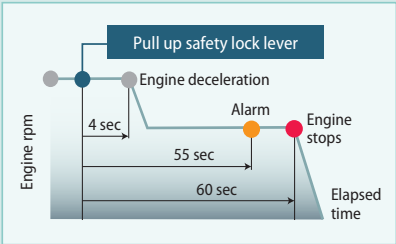

The significant reduction of in-line resistance and pressure loss boosts fuel efficiency. The electronic-control common-rail engine features high-pressure fuel injection and multiple injection with improved precision. It is fitted with an EGR cooler which greatly reduce PM and NOx emissions and meets Stage IV Standards.



## Engine meets Stage IV Standards

### Reduces Fuel Consumption and Minimizes Exhaust Emissions

Hino engines are renowned for fuel efficiency and environmental performance, and Kobelco has tuned these power plants especially for construction machinery. The pressure within the common rail fuel injection system, the VG turbo, and the exhaust gas after-treatment system reduce exhaust PM\*<sup>1</sup> while the large-capacity EGR cooler sharply reduces the formation of NOx gases.

\*<sup>1</sup> PM: Particulate Matter

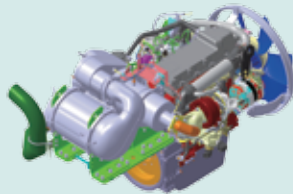

### VG Turbo Reduces PM

The variable-geometry turbocharger adjusts air intake to maximize combustion efficiency.

At low engine speeds the nozzles are closed, the turbo speed increased and air intake is boosted. This helps lower fuel consumption.

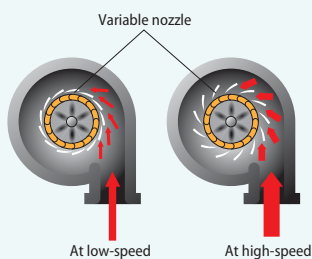

### SCR\*<sup>2</sup> System with DEF/Urea NEW

The engine exhaust system has an SCR system that converts NOx emissions into harmless nitrogen and water. Combining this with a post-exhaust gas treatment system that captures and disposes of PM, the SK180LC/SK180N has a much cleaner exhaust that meets Stage IV exhaust emission standards.

\*<sup>2</sup> SCR: Selective Catalytic Reduction

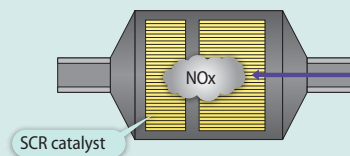

### EGR Cooler Reduces NOx

While ensuring sufficient oxygen for combustion, cooled emission gases are mixed with the air intake and re-circulated into the engine. The lowered oxygen temperature lowers the combustion temperature and increases combustion efficiency.

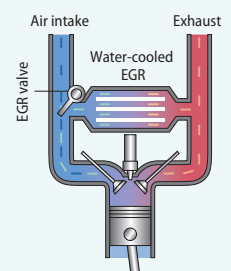

# More Power and Higher Efficiency

The highly efficient hydraulic system minimizes fuel consumption while maximizing power. With nimble movement and ample digging power, this excavator promises to improve your job productivity.

## Improved Fuel Efficiency Contributes to High Performance

### Superior Digging Volume

Powerful digging force delivers outstanding performance.

■ Max. Bucket Digging Force

Normal: **114 kN**

With Power Boost: **126 kN**

■ Max. Arm Crowding Force

Normal: **82.3 kN**

With Power Boost: **90.6 kN**



## Get More Done Faster with Superior Operability

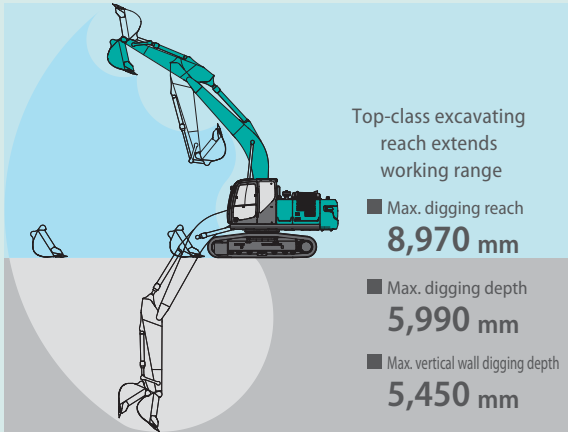

\*Values are for STD arm (2.6 m)

### Piping for Quick Hitch



A quick hitch hydraulic line, which speeds up attachment changes, is equipped as standard.

### A Light Touch on the Lever Means Smoother, Less Tiring Work **NEW**



It takes 25% less effort to work the operation lever, which reduces fatigue over long working hours or continued operations.

### Top Class Traveling Force

Powerful traveling force and drawbar pulling force deliver plenty of speed when climbing slopes or negotiating bad roads, and the agility to change direction swiftly and smoothly.

■ Drawbar Pulling Force: **231 kN**



## Operator-friendly Features Include Controls that Are Easy to See, Easy to Use



### Multi-Display in Color

Brilliant colors and graphic displays are easy to recognize on the LCD multi-display in the console. The display shows fuel consumption, maintenance intervals, and more.

- 1 Analog gauge provides an intuitive reading of fuel level and engine water temperature
- 2 Green indicator light shows low fuel consumption during operation
- 3 PM accumulation display (left)/ Urea level gauge (right)
- 4 Fuel consumption
- 5 Digging mode switch
- 6 Monitor display switch

### One-Touch Attachment Mode Switch

A simple flick of a switch converts the hydraulic circuit and flow amount to match attachment changes. Icons help the operator to confirm the proper configuration at a glance.



PM accumulation/  
Urea accumulation display



Fuel consumption

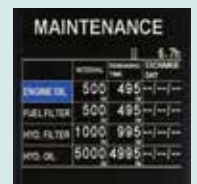

Maintenance

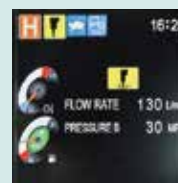

Breaker mode



Nibbler mode

# Increased Power, with Enhanced Durability to Maintain the Machine's Value

## Improved Filtration System Reliability

Clean, contaminant-free fuel and hydraulic fluid are essential to stable performance. The improved filtration systems reduce the risk of mechanical trouble and enhance longevity and durability.

### Hydraulic Fluid Filter **NEW**

Recognized as the best in the industry, our premium-fine filter separates out even the smallest particles. New cover prevents contamination when changing filters.



### Hydraulic Fluid Filter Clog Detector **NEW**

Pressure sensors at the inlet and outlet of the hydraulic fluid filter monitor differences in pressure to determine the degree of clogging. If the difference in pressure exceeds a predetermined level, a warning appears on the multi-display, so any contamination can be removed from the filter before it reaches the hydraulic fluid reservoir.

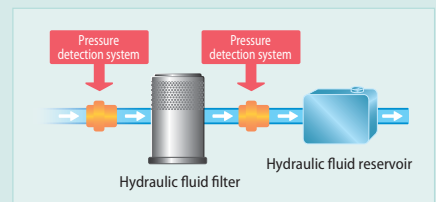

### Double-Element Air Cleaner **NEW**

The large-capacity element features a double-filter structure that keeps the engine running clean even in industrial environments.



### Fuel Filter

The pre-filter, with built-in water separator, is a new addition that features a final stage to maximize filtering performance.

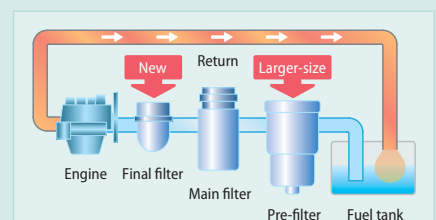



Increase in  
productivity  
means  
"Power"

Structural design increases strength, while eliminating hydraulic problems. Enhanced durability takes productivity to a new level.



## Built to Operate in Tough Working Environments

### 500 Hour Attachment Lubrication Interval

The self-lubrication bushings are used at the attachment pins and the bushings with high abrasion resistant property are used at the pins around the bucket. The lubrication cycle of the lubrication points around the bucket is 250 hours and that of other lubrication points is 500 hours.



\*Additionally the two piece bucket bushings protect the side of the arm from contact and then wear from the bucket ears. Should the bucket bushings need replacement, they can be replaced separately from the larger main bushing, reducing costs.

### Reliable Construction

Forged and cast components are used throughout. Under-side of arm reinforced with a rock guard to prevent damage to arm. Track guides help prevent the crawlers from coming off the rollers.



Reinforced arm with rock guard

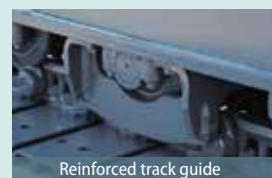

Reinforced track guide

# Comfortable Cab is Now Safer than Ever

A work environment that is quieter and more comfortable. A cab that puts the operator first is key to improved safety.



The picture is optional air suspension seat.



## Comfort

### Super-Airtight Cab



The high level of air-tightness keeps dust out of the cab.

### Quiet Inside

The high level of air-tightness ensures a quiet, comfortable cabin interior.

### Low Vibration

Coil springs absorb small vibrations, and high suspension mounts filled with silicone oil reduce heavy vibration. The long stroke achieved by this system provides excellent protection from vibration.

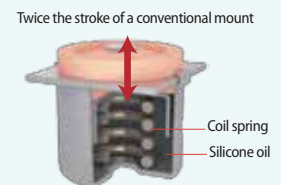

### Broad View Liberates the Operator

The front window features one large piece of glass without a center pillar on the right side for a wide, unobstructed view.

## Air Conditioner Register behind the Seat

NEW



The large air-conditioner has registers on the back pillars that blow from behind and to the right and left of the operator's seat. They can be adjusted to put a direct flow of cool/warm air on the operator, which means a more comfortable operating environment.

## More Comfortable Seat Means Higher Productivity



Seat suspension absorbs vibration



Seat recliner can be pushed back flat



Double slides allow adjustment for optimum comfort



## Large Cab Is Easy to Get in and Out of

The expanded cab provides plenty of room for a large door, more headroom and smoother entry and exit.

## Interior Equipment Adds to Comfort and Convenience



### Bluetooth Installed Radio

Bluetooth installed to allow connections with smartphones and other devices.



USB pin/12V power outlet



Spacious storage tray



Large cup holder

## Safety

### ROPS Cab

ROPS (Roll-Over-Protective Structure)-compliant cab clears ISO standards (ISO-12117-2: 2008) and ensures greater safety for the operator should the machine tip over.



TOP Guard is fitted as standard.



### Expanded Field of View for Greater Safety

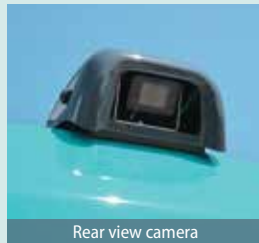

Rear view camera



Monitor Rear Right



Right side camera

### Right Side Camera Fitted as Standard

Further to the existing rear-view camera, a camera for the right side is fitted as standard for easy safety checks all round the machine.



Rearview mirror



Rear view

Greater safety assured by rearview mirror.

Rear view shows the area directly behind the cab.



Hammer for emergency exit

# KOMEXS

## KOBELCO MONITORING EXCAVATOR SYSTEM



### Remote Monitoring for Peace of Mind

KOMEXS (Kobelco Monitoring Excavator System) uses satellite communication and internet to relay data, and therefore can be deployed in areas where other forms of communication are difficult. When a hydraulic excavator is fitted with this system, data on the machine's operation, such as operating hours, location, fuel consumption, and maintenance status can be obtained remotely.

## Direct Access to Operational Status

### Location Data

Accurate location data can be obtained even from sites where communications are difficult.

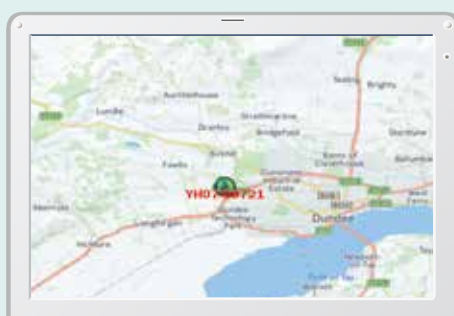

Latest location

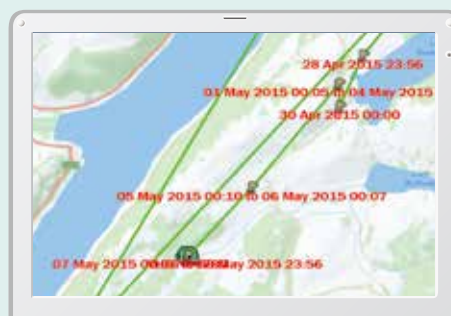

Location records

Type of Operation	Working Hrs	Ratio
Total Working Hrs	169 Hrs	100 %
Dipping Hrs	72.2 Hrs	43 %
Traveling Hrs	18.3 Hrs	11 %
Idle Hrs	15.9 Hrs	9 %
Opt Alt Hrs	62.5 Hrs	37 %
Crane Mode Hrs	0 Hrs	0 %

Work data

## Operating Hours

- A comparison of operating times of machines at multiple locations shows which locations are busier and more profitable.
- Operating hours on site can be accurately recorded, for running time calculations needed for rental machines, etc.

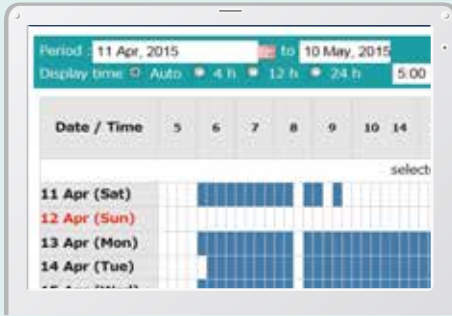

Daily report

## Fuel Consumption Data

Data on fuel consumption and idling times can be used to indicate improvements in fuel consumption.

Work mode	Working Hrs	Total Fuel Consumption
H mode	2:06	24.5 L
S mode	0:00	0.0 L
E mode	169:19	1489.7 L
<b>TOTAL</b>	<b>171:25</b>	<b>1514.2 L</b>

Fuel consumption

## Graph of Work Content

The graph shows how working hours are divided among different operating categories, including digging, idling, traveling and optional operations.

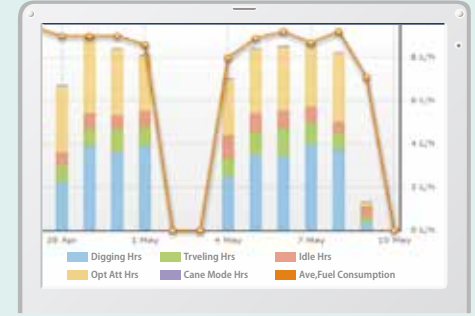

Work status

## Maintenance Data and Warning Alerts

### Machine Maintenance Data

- Provides maintenance status of separate machines operating at multiple sites.
- Maintenance data is also relayed to KOBELCO service personnel, for more efficient planning of periodic servicing.

Model	Serial No.	Hour Meter	Engine Oil
SK135SRLC-3/SK140SRL	YH07-09221	734 Hr	434
SK135SRLC-3/SK140SRL	YH07-09289	73 Hr	429
SK210LC-9	YQ13-10454	960 Hr	58
SK210LC-9	YQ13-10481	549 Hr	498
SK75SR-	YT08-20374		

Maintenance

### Warning Alerts

This system warns an alert if an anomaly is sensed, preventing damage that could result in machine downtime.

## Alarm Information Can Be Received through E-mail

Alarm information or maintenance notice can be received through E-mail, using a computer or cell phone.



Alarm messages can be received on mobile device.

## Daily/Monthly Reports

Operational data downloaded onto a computer helps in formulating daily and monthly reports.

## Security System

### Engine Start Alarm

The system can be set an alarm if the machine is operated outside designated time.

Engine start alarm outside prescribed work time

### Area Alarm

It can be set an alarm if the machine is moved out of its designated area to another location.

Alarm for outside of reset area



## Easy, On-the-Spot Maintenance NEW

There is ample space in the engine compartment for a mechanic to do maintenance work inside. The distance between steps is lower so entry and exit is easier. And the mechanic can work in comfort, without contortions or unnatural body positions. Finally, the hood is lighter and easier to raise and lower.

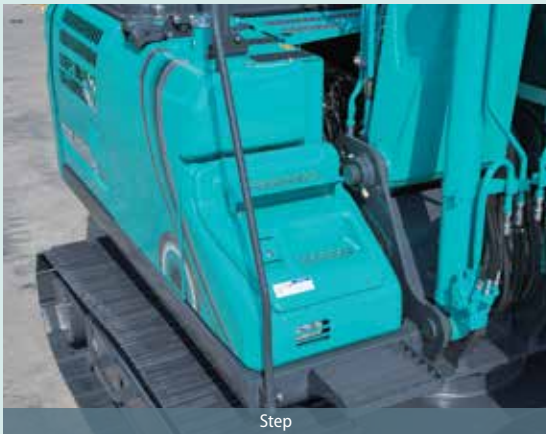

Step



Handrail



DEF/Urea tank

Positioned where the step opens.

## Maintenance Work, Daily Checks, Etc., Can Be Done from Ground Level

The layout allows for easy access from the ground for many daily checks and regular maintenance tasks.



Left side



Fuel filter with built-in water separator



Pre-fuel filter with built-in water separator

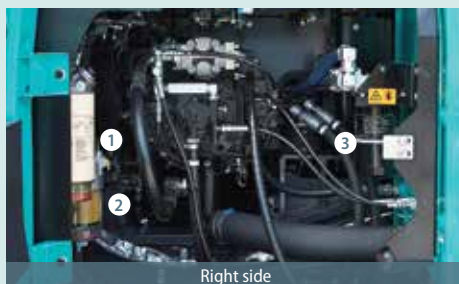

Right side



Engine oil filter

Laid out for easy access to radiator and cooling system elements

- ① Fuel filter with built-in water separator
- ② Pre-fuel filter with built-in water separator
- ③ Engine oil filter

# Efficient Maintenance Keeps the Machine in Peak Operating Condition



## Machine Information Display Function

Examples of displaying maintenance information

- Displays only the maintenance information that's needed, when it's needed
- Self-diagnostic function provides early-warning detection and display of electrical system malfunctions
- Service-diagnostic function makes it easier to check the status of the machine
- Record function of previous breakdowns including irregular and transient malfunction

## More Efficient Maintenance Inside the Cab



Easy-access fuse box



Air conditioner filters

More finely differentiated fuses make it easier to locate malfunctions. Internal and external air conditioner filters can be easily removed without tools for cleaning.

## Easy Cleaning



Crawler frame



Detachable two-piece floor mat

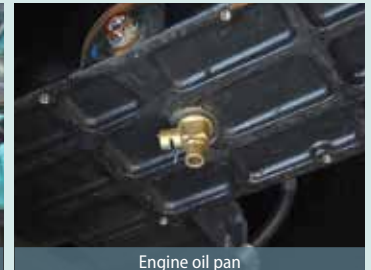

Engine oil pan

Special crawler frame design is easily cleaned of mud. Detachable two-piece floor mat with handles for easy removal. A floor drain is located under floor mat. Engine oil pan equipped with drain valve.

Long-life hydraulic oil:  
**5,000**  
hours

## Long-Interval Maintenance

Long-life hydraulic oil reduces cost and labor.

Replacement cycle:  
**1,000**  
hours

## Highly Durable Premium-fine Filter

The high-capacity hydraulic oil filter incorporates glass fiber with superior cleaning power and durability.





## Engine

Model	HINO J05EUM-KSST
Type	Direct injection, water-cooled, 4-cycle diesel engine with intercooler, turbocharger (complies with EU (NRMM) Stage IV)
No. of cylinders	4
Bore and stroke	112 mm x 130 mm
Displacement	5.123 L
Rated power output	95 kW/2,000 min <sup>-1</sup> (ISO 9249)
	100 kW/2,000 min <sup>-1</sup> (ISO14396)
Max. torque	482 N-m/1,600 min <sup>-1</sup> (ISO 9249)
	502 N-m/1,600 min <sup>-1</sup> (ISO 14396)



## Hydraulic System

Pump	
Type	Two variable displacement pumps + One gear pump
Max. discharge flow	2 x 160 L/min, 1 x 20 L/min
Relief valve setting	
Boom, arm and bucket	34.3 MPa
Power Boost	37.8 MPa
Travel circuit	34.3 MPa
Swing circuit	28.0 MPa
Control circuit	5.0 MPa
Pilot control pump	Gear type
Main control valves	8-spool
Oil cooler	Air cooled type



## Swing System

Swing motor	Axial piston motor
Parking brake	Oil disc brake, hydraulic operated automatically
Swing speed	12.3 min <sup>-1</sup>
Swing torque	52.6 kN-m
Tail swing radius	2,550 mm
Min. front swing radius	2,710 mm



## Attachments

Backhoe bucket and combination

Type	Backhoe bucket		
Bucket capacity	ISO heaped	m <sup>3</sup>	0.63
	ISO Struck	m <sup>3</sup>	0.45
Opening width	With side cutter	mm	1,075
	Without side cutter	mm	975
Bucket weight		kg	500
Combination	2.6 m standard arm		○
	3.1 m long arm		○

○ Standard



## Travel System

Travel motors	2 x axial piston , two speed motors
Parking brakes	Oil disc brake per motors
Travel shoes	49 each side (SK180LC)
	45 each side (SK180N)
Travel speed	4.7/2.8 km/h
Drawbar pulling force	231 kN (ISO 7464)
Gradeability	70 % {35 deg}
Ground clearance	460 mm



## Cab & Control

Cab	
All-weather, sound-suppressed steel cab mounted on the silicon-sealed suspension mounts and equipped with a heavy, insulated floor mat.	
Control	
Two hand levers and two foot pedals for travel	
Two hand levers for excavating and swing	
Electric rotary-type engine throttle	
Noise Levels	
External	102 dB (ISO 6395)
Operator	68 dB (ISO 6396)



## Boom, Arm & Bucket

Boom cylinder	110 mm x 1,156 mm
Arm cylinder	125 mm x 1,285 mm
Bucket cylinder	105 mm x 1,025 mm



## Refilling Capacities & Lubrications

Fuel tank	280 L
Cooling system	19 L
Engine oil	20.5 L
Travel reduction gear	2 x 5.0 L
Swing reduction gear	2.7 L
Hydraulic oil tank	122 L tank oil level
	200 L hydraulic system
DEF/Urea tank	33.9 L





## Working Ranges

Unit: m

Boom	5.2 m	
Arm length	Standard 2.6 m	Long 3.1 m
a- Max. digging reach	8.97	9.49
b- Max. digging reach at ground level	8.80	9.32
c- Max. digging depth	5.99	6.49
d- Max. digging height	9.35	9.77
e- Max. dumping clearance	6.70	7.10
f- Min. dumping clearance	2.65	2.15
g- Max. vertical wall digging depth	5.45	5.95
h- Min. swing radius	2.71	2.74
i- Horizontal digging stroke at ground level	4.49	5.35
j- Digging depth for 8' (2.4 m) flat bottom	5.76	6.31
Bucket capacity (ISO heaped)	0.63 m <sup>3</sup>	0.63 m <sup>3</sup>

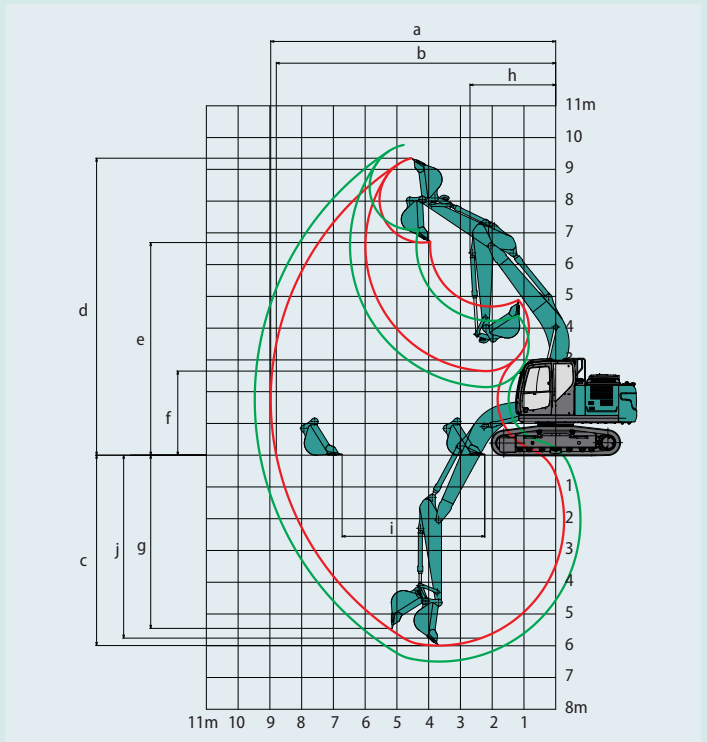

## Digging Force (ISO 6015)

Unit: kN

Boom	5.2 m	
Arm length	Standard 2.6 m	Long 3.1 m
Bucket digging force	114	114
	126*	126*
Arm crowding force	82.3	71.7
	90.6*	78.8*

\*Power Boost engaged.

— Standard Arm — Long Arm



## Dimensions

Arm length		Standard 2.6 m	Long 3.1 m
A Overall length		8,700	8,710
B Overall width of crawler	SK180LC	2,800	
	SK180N	2,490	
C Overall height (to top of hand rail)		3,080	
D Ground clearance of rear end*		1,050	
E Ground clearance*		460	
F Tail swing radius		2,550	
F' Distance from center of swing to rear end		2,550	

Unit: mm

G Tumbler distance	SK180LC	3,660
	SK180N	3,280
H Overall length of crawler	SK180LC	4,450
	SK180N	4,070
I Track gauge	SK180LC	2,200
	SK180N	1,990
J Shoe width	SK180LC	600
	SK180N	500
K Overall width of upperstructure		2,490

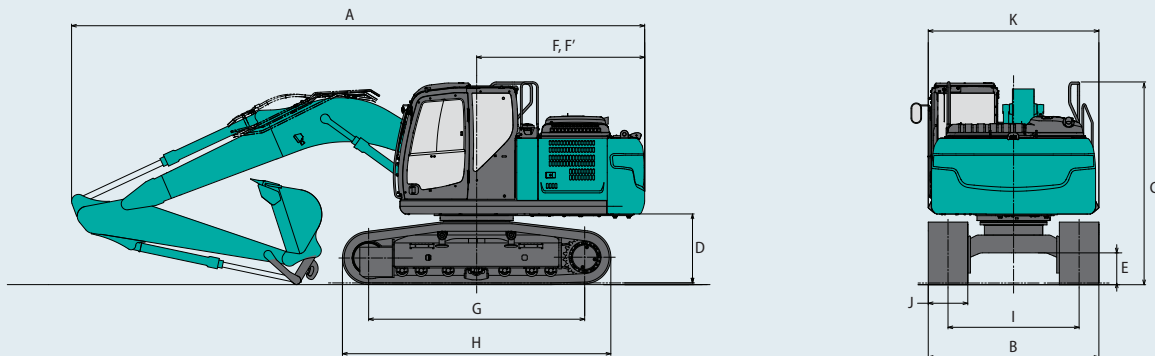

## Operating Weight & Ground Pressure

In standard trim, with standard boom, 2.6m arm, and 0.63 m<sup>3</sup> ISO heaped bucket

Shaped	Triple grouser shoes (even height)						
Shoe width		mm	500	600	700	790	900
Overall width of crawler	SK180LC	mm	—	2,800	2,900	2,990	3,100
	SK180N	mm	2,490	2,590	2,690	2,780	—
Ground pressure	SK180LC	kPa	—	41	36	32	28
	SK180N	kPa	52	44	38	34	—
Operating weight	SK180LC	kg	—	19,600	20,000	20,200	20,500
	SK180N	kg	18,800	19,000	19,400	19,600	—

# Lifting Capacities

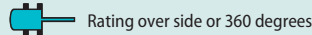
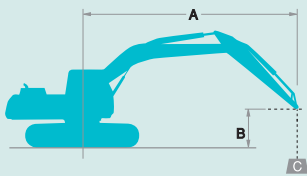

A – Reach from swing centerline for arm top  
 B – Arm top height above/below ground  
 C – Lifting capacities in kilograms  
 \* Max. discharge pressure: 37.8 MPa

SK180LC		Standard Arm: 2.6 m Bucket: without Shoe: 600 mm										HEAVY LIFT		
A \ B		1.5 m		3.0 m		4.5 m		6.0 m		7.5 m		At Max. Reach		Radius
7.5 m	kg					*4,320	*4,320					*3,100	*3,100	4.96 m
6.0 m	kg							*3,930	*3,930			*2,770	*2,770	6.32 m
4.5 m	kg					*5,430	*5,430	*4,750	4,190			*2,700	*2,700	7.11 m
3.0 m	kg			*10,260	*10,260	*6,600	6,150	*5,220	4,020	*2,930	2,860	*2,770	*2,770	7.52 m
1.5 m	kg					*7,670	5,750	*5,700	3,840	*3,840	2,790	*2,990	2,730	7.61 m
G. L.	kg			*7,330	*7,330	*8,100	5,520	*5,940	3,710			*3,400	2,790	7.40 m
-1.5 m	kg	*7,010	*7,010	*11,130	10,290	*7,790	5,460	*5,720	3,670			*4,220	3,080	6.86 m
-3.0 m	kg	*11,550	*11,550	*9,160	*9,160	*6,620	5,540					*4,670	3,840	5.89 m
-4.5 m	kg			*5,500	*5,500							*3,960	*3,960	4.21 m

SK180LC		Long Arm: 3.1 m Bucket: without Shoe: 600 mm										HEAVY LIFT		
A \ B		1.5 m		3.0 m		4.5 m		6.0 m		7.5 m		At Max. Reach		Radius
7.5 m	kg											*2,260	*2,260	5.73 m
6.0 m	kg							*3,910	*3,910			*2,040	*2,040	6.93 m
4.5 m	kg					*4,870	*4,870	*4,370	4,240	*2,630	*2,630	*1,970	*1,970	7.66 m
3.0 m	kg			*8,960	*8,960	*6,070	*6,070	*4,900	4,050	*3,950	2,860	*2,000	*2,000	8.04 m
1.5 m	kg			*7,790	*7,790	*7,290	5,800	*5,460	3,840	*4,510	2,770	*2,130	*2,130	8.13 m
G. L.	kg			*7,550	*7,550	*7,960	5,500	*5,830	3,680	4,560	2,700	*2,370	*2,370	7.93 m
-1.5 m	kg	*6,000	*6,000	*10,460	10,150	*7,900	5,390	*5,790	3,610			*2,830	2,710	7.43 m
-3.0 m	kg	*9,530	*9,530	*10,060	*10,060	*7,060	5,430	*5,070	3,640			*3,790	3,260	6.55 m
-4.5 m	kg			*7,050	*7,050	*4,910	*4,910					*3,980	*3,980	5.09 m

SK180N		Standard Arm: 2.6 m Bucket: without Shoe: 500 mm										HEAVY LIFT		
A \ B		1.5 m		3.0 m		4.5 m		6.0 m		7.5 m		At Max. Reach		Radius
7.5 m	kg					*4,320	*4,320					*3,100	*3,100	4.96 m
6.0 m	kg							*3,930	3,760			*2,770	*2,770	6.32 m
4.5 m	kg					*5,430	*5,430	*4,750	3,680			*2,700	*2,700	7.11 m
3.0 m	kg			*10,260	9,740	*6,600	5,350	*5,220	3,520	*2,930	2,490	*2,770	2,480	7.52 m
1.5 m	kg					*7,670	4,960	5,450	3,340	*3,840	2,420	*2,990	2,370	7.61 m
G. L.	kg			*7,330	*7,330	*8,100	4,740	*5,310	3,210			*3,400	2,410	7.40 m
-1.5 m	kg	*7,010	*7,010	*11,130	8,650	*7,790	4,690	5,260	3,170			*4,220	2,670	6.86 m
-3.0 m	kg	*11,550	*11,550	*9,160	8,840	*6,620	4,760					*4,670	3,330	5.89 m
-4.5 m	kg			*5,500	*5,500							*3,960	*3,960	4.21 m

SK180N		Long Arm: 3.1 m Bucket: without Shoe: 500 mm										HEAVY LIFT		
A \ B		1.5 m		3.0 m		4.5 m		6.0 m		7.5 m		At Max. Reach		Radius
7.5 m	kg											*2,260	*2,260	5.73 m
6.0 m	kg							*3,910	3,820			*2,040	*2,040	6.93 m
4.5 m	kg					*4,870	*4,870	*4,370	3,720	*2,630	2,560	*1,970	*1,970	7.66 m
3.0 m	kg			*8,960	*8,960	*6,070	5,450	*4,900	3,540	*3,950	2,490	*2,000	*2,000	8.04 m
1.5 m	kg			*7,790	*7,790	*7,290	5,010	5,460	3,340	3,890	2,400	*2,130	2,120	8.13 m
G. L.	kg			*7,550	*7,550	*7,960	4,730	5,280	3,180	3,810	2,330	*2,370	2,150	7.93 m
-1.5 m	kg	*6,000	*6,000	*10,460	8,510	*7,900	4,620	5,200	3,110			*2,830	2,340	7.43 m
-3.0 m	kg	*9,530	*9,530	*10,060	8,650	*7,060	4,650	*5,070	3,140			*3,790	2,810	6.55 m
-4.5 m	kg			*7,050	*7,050	*4,910	4,850					*3,980	*3,980	5.09 m

**Notes:**

- Do not attempt to lift or hold any load that is greater than these lifting capacities at their specified lifting point radius and heights. Weight of all accessories must be deducted from the above lifting capacities.
- Lifting capacities are based on machine standing on level, firm, and uniform ground. User must make allowance for job conditions such as soft or uneven ground, out of level conditions, side loads, sudden stopping of loads, hazardous conditions, experience of personnel, etc.
- Arm top defined as lift point.
- The above lifting capacities are in compliance with ISO 10567. They do not exceed 87% of hydraulic lifting capacity or 75% of tipping load. Lifting capacities marked with an asterisk (\*) are limited by hydraulic capacity rather than tipping load.
- Operator should be fully acquainted with the Operator's and Maintenance Instructions before operating this machine. Rules for safe operation of equipment should be adhered to at all times.
- Lifting capacities apply to only machine as originally manufactured and normally equipped by KOBELCO CONSTRUCTION MACHINERY CO., LTD.

## STANDARD EQUIPMENT

### ENGINE

- Engine, HINO J05EUM-KSST, diesel engine with turbocharger and intercooler
- Automatic engine deceleration
- Auto Idle Stop (AIS)
- Batteries (2 x 12V - 92Ah)
- Starting motor (24V - 5 kW), 60 amp alternator
- Automatic engine shut-down for low engine oil pressure
- Engine oil pan drain cock
- Double element air cleaner

### CONTROL

- Working mode selector (H-mode, S-mode and ECO-mode)
- Power Boost
- Heavy lift
- Extra N&B piping (proportional hand controlled)
- Object Handling Kit (boom and arm safety valve + hook)

### SWING SYSTEM & TRAVEL SYSTEM

- Swing rebound prevention system
- Straight propel system
- Two-speed travel with automatic shift down
- Sealed & lubricated track links
- Grease-type track adjusters
- Automatic swing brake

### HYDRAULIC

- Arm regeneration system
- Auto warm up system
- Aluminum hydraulic oil cooler
- Quick Hitch piping

### MIRRORS, LIGHTS AND CAMERAS

- Rear view mirrors
- Rear & right view camera
- Three front working lights (two for boom and one for right storage box)

### CAB & CONTROL

- Two control levers, pilot-operated
- Tow eyes
- Horn, electric
- Cab light (interior)
- Luggage tray
- Large cup holder
- Detachable two-piece floor mat
- Headrest
- Handrails
- Intermittent windshield wiper with double-spray washer
- Skylight
- Tinted safety glass
- Pull-up type front window and removable lower front window
- Easy-to-read multi-display color monitor
- Automatic air conditioner
- Emergency escape hammer
- Air suspension seat with heater
- Radio, AM/FM stereo with speaker
- Emergency escape hammer
- Top guard (ISO 10262:1998)
- Remote machine monitoring system "KOMEXS"

## OPTIONAL EQUIPMENT

- Wide range of shoes
- Additional track guide
- N&B piping
- Two cab lights
- Mechanical suspension seat (optional for N&B specification)
- Rain visor (may interfere with bucket action)
- Bigger capacity P4 pump and steel PTO housing
- Lower under cover
- Front-guard protective structure (may interfere with bucket action)

Note: Standard and optional equipment may vary. Consult your KOBELCO dealer for specifics.

Note: This catalog may contain attachments and optional equipment that are not available in your area. And it may contain photographs of machines with specifications that differ from those of machines sold in your areas. Please consult your nearest KOBELCO distributor for those items you require. Specialist equipment is needed to use this machine in demolition work. Before using it please contact your KOBELCO dealer. Due to our policy of continuous product improvements all designs and specifications are subject to change without advance notice.

Copyright by **KOBELCO CONSTRUCTION MACHINERY CO., LTD.** No part of this catalog may be reproduced in any manner without notice.

**KOBELCO CONSTRUCTION MACHINERY EUROPE B.V.**

Veluwezoom 15  
1327 AE Almere  
The Netherlands  
[www.kobelco-europe.com](http://www.kobelco-europe.com)

Inquiries To: